

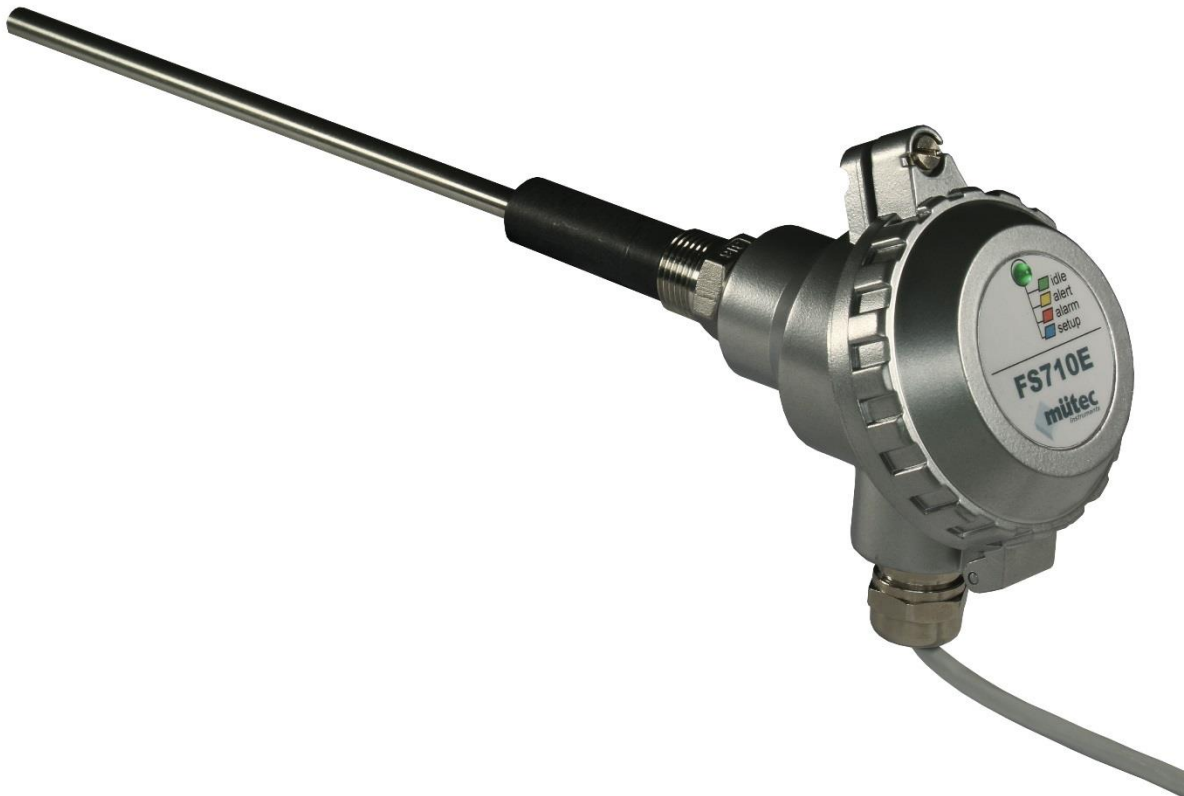

Operating Manual FS710E



**Dust monitoring
with two switch outputs
for the detection of
filter malfunctions**

	Operating Manual MSBA00042	Date: 21.03.2019 Rev.: 06 Page 2 von 13
	Operating Manual FS710E	

Operating Manual for FS710E

No.: MSBA00042-06
Issue date: 03/2019

Manufacturer:

Mütec Instruments GmbH
Bei den Kämpfen 26
21220 Seevetal
Deutschland

Tel.: +49 (0) 4185 8083-0
Fax: +49 (0) 4185 8083-80

E-Mail: info@muetec.de
Internet: www.muetec.de

Copyright © Mütec Instruments GmbH 2019 All rights reserved

This document is copyright protected. It supports the user in making reliable and efficient use of the unit. Transmission and duplication of this document as well as utilization and disclosure of its content are prohibited unless expressly permitted. Any breach or infringement shall result in liability for damages. The software described in this document is licensed and may only be used and copied in accordance with the terms of the license.

All rights reserved.

Disclaimer

We have checked the content of the printed document for compliance with the described hardware and software. Nevertheless, deviations cannot be excluded and consequently we cannot assume any guarantee for complete accordance. The data in this printed document are checked regularly. Corrections and additions are made in the following version in each case. We would be grateful for any suggestions for improvement.

© Mütec Instruments GmbH

Subject to technical modifications

06	21.03.2019	Update of cable screen, sensor rod diameter and material	J. Scholtyssek	C. Kutschker	A. Wist
05	10.10.2018	Update of cable, sensor rod and earthing connection	C. Kutschker	J. Scholtyssek	A. Wist
04	29.03.2018	Update in dimension drawing	J. Scholtyssek	C. Kutschker	A. Wist
03	12.12.2017	Added cable information	J. Scholtyssek	C. Kutschker	A.Wist
02	13.02.2017	Technical sketch revised	R. Gawron	J. Scholtyssek	H. Neumann
01	02.11.2016	Revised	A. Ohlendorf	J. Scholtyssek	H. Neumann
00	16.02.2016	Basic Version	A. Ohlendorf	J. Scholtyssek	H. Neumann
REV	DATE	DESCRIPTION	PRPD	CHKD	APPR

	Operating Manual MSBA00042	Date: 21.03.2019 Rev.: 06 Page 3 von 13
Operating Manual FS710E		

Table of Contents

1	Classification of the safety instructions	4
2	General instructions	5
3	Introduction	6
4	General information on construction and operation	7
5	Mounting instructions	8
5.1	Preparations for mounting sensors.....	8
5.2	Sensor Mounting	8
6	Electrical connection	9
7	Commissioning, calibration and operation	10
7.1	Commissioning.....	10
7.2	Calibration	10
7.3	Operation	11
8	Technical Data	12
9	Service and maintenance	13
10	Fault elimination.....	13
11	Disposal.....	13

Operating Manual FS710E

1 Classification of the safety instructions

This manual contains instructions that you have to observe for your personal safety as well as to avoid material damage. These instructions are highlighted using a triangular warning sign and shown as follows, depending on the degree of risk.



HAZARD

means that death or severe physical injury will occur if the appropriate precautionary measures are not taken.



WARNING

means that death or severe physical injury may occur if the appropriate precautionary measures are not taken.



CAUTION

with a triangular warning sign means that minor physical injury may occur if the appropriate precautionary measures are not taken.

CAUTION

without a triangular warning sign means that material damage may occur if the appropriate precautionary measures are not taken.



ATTENTION

means that an undesired result or state may ensue if the corresponding instruction is not followed.



NOTE

denotes important information about the product, handling of the product or the respective part of the documentation, is aimed at drawing special attention to the latter and should be complied with.

In addition to the instructions in this manual, the generally applicable safety and accident prevention regulations must be observed.

If the information contained in this document should not be sufficient in any specific case, you can obtain more detailed information from our telephone service.

Please read this manual carefully prior to installation and commissioning.

CE mark

This product meets the specifications according to the EMC Directive 2014/30/EU and the Low Voltage Directive 2014/35/EU.

	Operating Manual MSBA00042	Date: 21.03.2019 Rev.: 06 Page 5 von 13
Operating Manual FS710E		

2 General Instructions

This device left the plant in flawless condition in terms of its safety features. To preserve this condition and ensure safe operation of the device, the user has to observe the instructions and warning notes indicated in this operating manual.

NOTE



For the sake of clarity the manual does not contain complete detailed information on all product types and can therefore not take into account every conceivable case with respect to installation, operation and maintenance.

Should you wish further information or should special problems arise that are not treated in sufficient detail in the manual, you can obtain the necessary information by telephone. Moreover, we point out that the content of the manual shall not constitute part of or amend a previous or existing contract, agreement or legal relationship. All obligations of Mütec Instruments GmbH shall result from the respective contract of purchase, which also contains the complete and solely valid warranty terms. These contractual warranty terms shall neither be extended nor limited by the information contained in the manual. The content reflects the technical state of the art regarding printing. It is subject to technical modifications in the course of further development.

DISCLAIMER

All modifications to the device fall within the responsibility of the user unless expressly specified otherwise in the operating manual.

QUALIFIED PERSONNEL

are persons who are familiar with installation, assembly, repair and operation of the product and have the qualifications necessary for their work, such as:

- Training, instruction and/or authorization to operate and maintain equipment/systems in accordance with the standards of safety technology for electrical circuits, high pressures and corrosive as well as hazardous media.
- In the case of equipment with explosion protection: training, instruction and/or authorization to perform work on electrical circuits for potentially explosive equipment.
- Training or instruction in accordance with the standards of safety technology regarding care and use of appropriate safety equipment.

CAUTION

Potentially electrostatic components may be destroyed by voltage that is far below the limits of human perception. Such voltage occurs even when you touch a component or electrical connections of a component and are not electrostatically discharged. The damage that occurs to a component because of overvoltage usually cannot be detected immediately and does not become noticeable until after a longer operating period.

Operating Manual FS710E

3 Introduction

The dust indicator FS710E is intended for the use at the clean air side to detect dust behind a filter. In this way, filter cracks, fractures or assembly errors are reported automatically and reliably.

The FS710 is suitable for all piping and metallic channels, whose length exceed 3 times the diameter. Installation is quick and easy by welding a threaded sleeve. The sensor rod is inserted into the pipe and fixed by the thread.

The sensor rod length should be at least 1/3 of the pipe diameter and must not touch the opposite wall. A distance of min. 20mm is recommended between the rod end and the opposite wall.

The measurement system is based on the triboelectric effect: Particles collide permanently with each other or with other materials, e.g. the wall. Because of this process the particles will be charged in a natural way. If these electrically charged particles are flying next to the sensor rod of FS710E or even touch it, the particles are detected via the charge transfer. Resting particles, such as deposits etc., do not affect the measurement. Therefore a subsequent installation into existing exhaust ducts is possible without any problems.

The device cannot be used for material which forms an electrically conductive layer between the sensor rod and inner wall by abrasion or adhesions.

Features

- Automatic calibration
- Maintenance free
- Three-condition monitoring
- Two switching points via switch output
- Condition indication by different LED colors
- Compact form
- Protection class IP65
- Easy installation

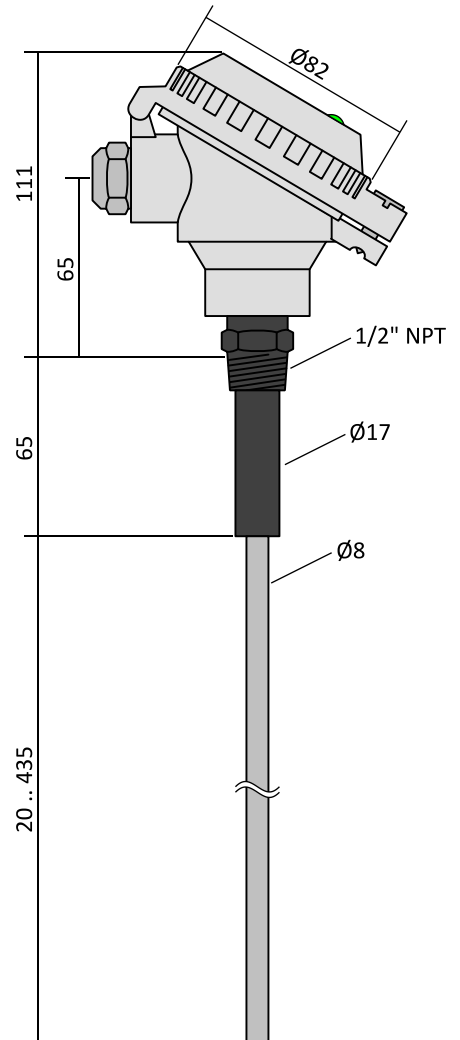



Figure 1 – Dimensions (in mm)

	Operating Manual MSBA00042	Date: 21.03.2019 Rev.: 06 Page 7 von 13
Operating Manual FS710E		

4 General information on construction and operation

Safety instructions

If the device can no longer be operated safely, it must be put out of operation and secured to prevent unintentional operation. The reasons for this may include:

- Visible damage to the device
- Failure or malfunction
- Storage or operation outside the approved temperature range
- Moisture inside the device
- Severe transport stress

Before the device is put into operation again, a professional routine test must be performed in accordance with DIN EN 61010, Part 1. This test should be performed by the manufacturer.

Intended use

The FS710 based on the triboelectric effect detects malfunction at filters, e.g. filter breaks or assembly errors.

The sensor has two switch outputs which are realized as solid state relays. Therefore the technical data for current and voltage may not be exceeded.

Operating Manual FS710E

5 Mounting Instructions

5.1 Selection of the mounting position

The inlet and outflow zone for FS710E should not be less than 3 times the nominal diameter.

After fixing the threaded sleeve in a 90° angle to the tube axis, the mounted weld must close the gap between the sleeve and the pipe wall reliably.

The quality of the weld can be tested with a subsequent pressure test. The drilling of the tube wall for the required measurement window is performed with an 18 mm drill bit. Therefor the previously welded sleeve serves as a drilling template. After drilling, the borehole on the inner pipe wall needs to be trimmed as much as possible to ensure that material deposits cannot take place.

5.2 Sensor Mounting

For mounting sleeve need to be threaded on the tube in a 90° angle to the tube axis

The length of the sensor rod should be at least 1/3 of the inner diameter of the pipe. The sensor rod must not come in contact with the opposite wall or with other metallic parts. Therefore it is recommended to keep a minimum distance of 20mm between the opposite wall and the end of the sensor rod.

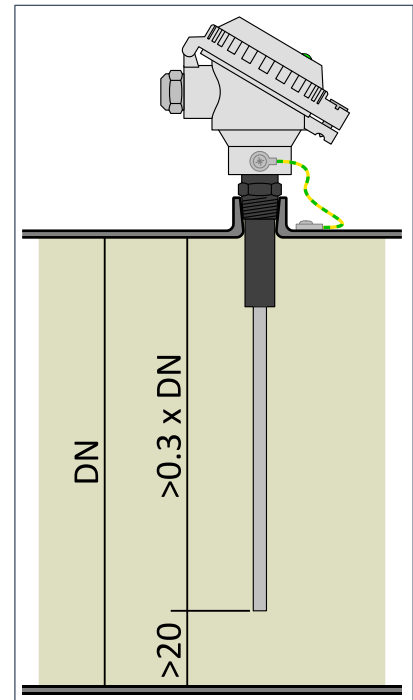

Figure 2a - Mounting

For proper device operation it is mandatory, to establish the earthing connection between the sensor enclosure and the installation location (pipe).

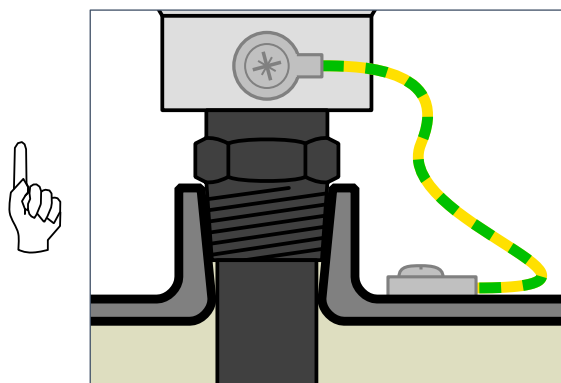

Figure 2b – Earthing connection

Operating Manual FS710E

6 Electrical Connection

The sensor is supplied with a pre-assembled connecting cable (length 3,0 m, Ø 5.9 mm, 8 x 0.14 mm², insulation: PVC or special halogen-free compound).

The description of the eight wires of this connection cable can be seen in Figure 3.







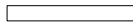

green		calibration (IN)
white		calibration (GND)
yellow		supply (+24V)
brown		supply (0V)
pink		solid state relay 1
red		solid state relay 1
grey		solid state relay 2
blue		solid state relay 2
black		cable screen

Figure 3 - 8-wire connection cable + cable screen

The block diagram (Figure 4) shows the connecting options of FS710E.

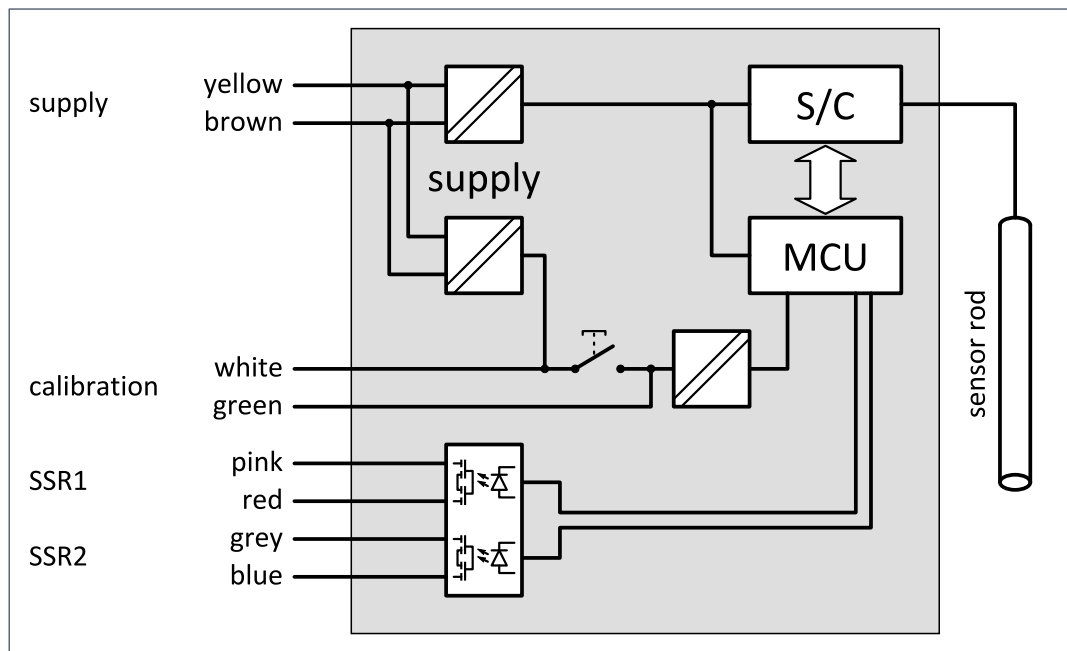

Figure 4 – Block diagram

Operating Manual FS710E

7 Commissioning, Calibration and Operation

7.1 Commissioning

Once the system is connected to the 24V supply, the *indicator LED* blinks blue for about one second. The switch outputs are opened during this time. Once the LED has changed the color, the device is ready for operation and calibration.

7.2 Calibration

The FS710E will be delivered pre-calibrated. If the particle load at the good condition is higher than foreseen at the pre-calibration, a recalibration can occur at any time to define a new good condition.

To activate the calibration, press the *calibration pushbutton* or connect the two *calibration wires*, green and green/white (see Figure 3).

The blinking LED indicates the begin of the calibration process. During the first minute no values will be recorded. Please close the cover and establish normal operating conditions in the meanwhile. After the minute, the LED switches to cyan. For the next ten minutes the device registers the signals caused by the dust load inside the pipe and defines a new good condition. Please avoid any irregularities in the process at this time and do not touch the unit. In case of too high readings (caused by touch or too high dust concentration), the device goes to the error state, indicated by a red blinking LED. This state can only be left by restarting the calibration or power cycle.

The switch outputs are opened during the entire calibration process. After the calibration has been completed, the device changes to the operation mode automatically.

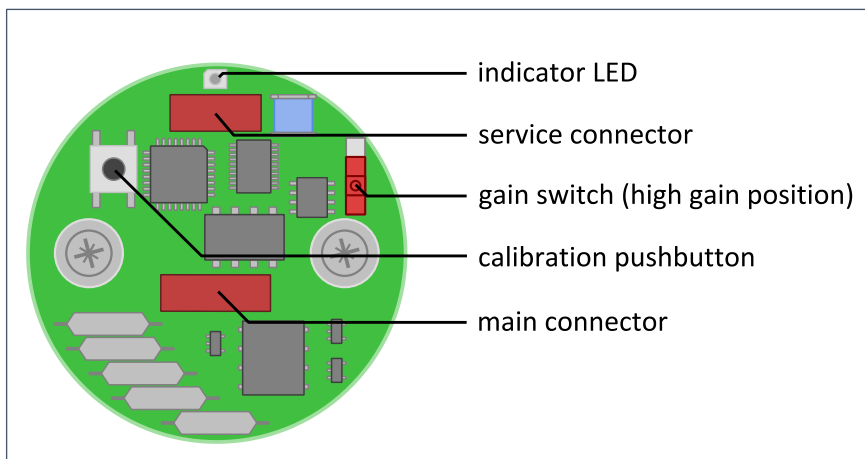

Figure 5 - View of board

7.3 Varification of the calibration

Once the system was calibrated successfully, a validation of the different alarm modes are recommended.

Therefor please increase the particle load at the measuring point manually and observe the switching points of the sensor. If particle load increases, LED's color will change from green (good condition) to yellow (pre alarm) and finally to red (main alarm).

7.4 Operation

The emerging particle load is continuously captured and classified in three different categories during the operation.

The load category depends on the particle load and is signaled both by the two switch outputs and the LED color, as shown in Table 1 below.

	Particle load	Status	LED	Switch output 1	Switch output 2
Load category I	low	Good condition	green	closed	closed
Load category II	medium	Pre alarm (Warning)	yellow	opened	closed
Load category III	high	Main alarm	red	closed	opened

Table 1 – Load categories

Operating Manual FS710E

8 Technical Data

Housing material:	Aluminum
Material sensor rod:	V2A / V4A (option)
Isolator:	PPS
Protection class:	IP65
Weight:	700g
Tightening torque - mounting:	40Nm
Storage temperature:	-20°C to +70°C (not condensing)
Operating temperature:	-20°C to +70°C
Process temperature:	-20°C to +150°C
Process pressure:	0 to 2 bar
Supply voltage:	24 VDC (18 VDC ... 26 VDC)
Power consumption:	max. 50 mA
Power:	< 2 W
Hysteresis:	fixed
Filter time:	fixed

Switch output 1 and switch output 2

Relay output:	Closed-circuit current principle
Switching voltage:	60 V AC/DC
Switching current:	max. 100 mA
Switching capacity:	6 W
Cable:	assembled



If the maximum permissible temperature is exceeded, the warranty expires.

	Operating Manual MSBA00042	Date: 21.03.2019 Rev.: 06 Page 13 von 13
Operating Manual FS710E		

9 Service and maintenance

When using the measuring device at abrasive materials, the product stream exposed areas must be regularly checked for their dimensions. The loss of material must not be more than 1mm.

The transmission of the devices remains reliable and stable over a long period, neither regular adjustments nor maintenances are required.

10 Fault Elimination

Remove the device as soon as a disturbance of the device is detected. Send the device to the manufacturer for maintenance.

11 Disposal

The disposal of packaging and used parts must be done in accordance with the provisions of the country in which the equipment is installed. In particular, electronic components that are to be disposed of, are classified as hazardous!